

---

# Online Conductivity Controller

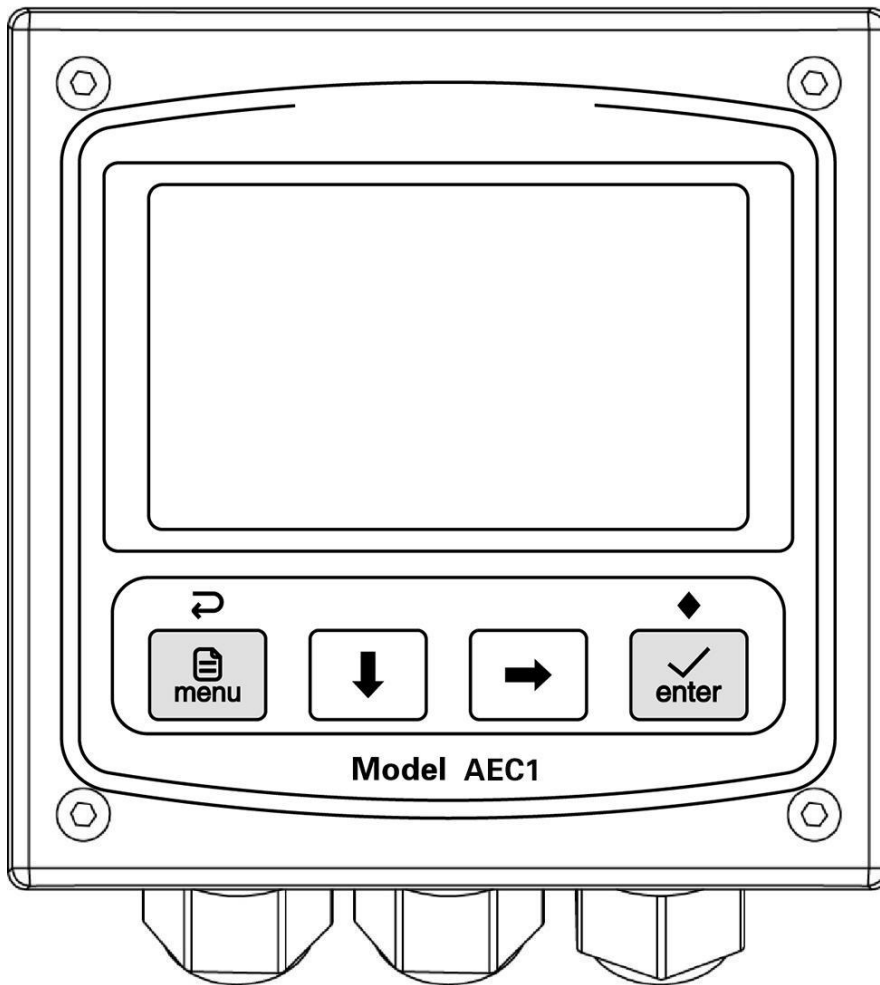

User Manual

---

## Important Safety Information

Please read and observe the following:

Please read this entire manual before unpacking, installation and operation, with particular attention to all danger warnings and precautions. Failure to do so may result in damage to the instrument or personal injury to the operator due to misuse. Do not install or use the instrument by any means other than those specified in this manual.

- After opening the analyzer case, the user may touch the instrument supply voltage. Please make sure to disconnect the power, before you open the analyzer cases. Analyzer housing assembly only low voltage, the operation is safe.
- The analyzer must be installed in accordance with relevant local codes and the professional and technical personnel, to comply with the analyzer's technical specifications and input ratings. If you are not sure which of the main power lines is the zero line, use a double-blade switch to disconnect the analyzer.
- As soon as a problem occurs with the analyzer, disconnect the analyzer from power to prevent any unintentional operation that could result in damage to the instrument. For example, it may be in an unsafe state when the following situations occur:
  - (1)The analyzer appears visibly damaged;
  - (2)Analyzer fails to operate properly or provide the intended measurements;
  - (3)Analyzer has been stored for a long period of time at temperatures over 70°C environment.
- Wiring or repair should be done by professionals, and only the power-off analyzer should be operated.

### Power Wiring Note

1. Please install voltage stabilization and surge protection equipment that meets the instrument parameters at the power supply terminal to ensure that the power supply provided by the instrument is stable and reliable and meets the standards, otherwise the instrument will be irreversibly damaged due to poor power supply.
2. Damage caused by incorrect power supply is not covered by our quality guarantee.
3. Detailed parameters see the technical parameters.

### Useful signs

In addition to installation and operation information, the manual also includes warning signs related to user safety, caution signs related to possible instrument failure, and note signs related to important and useful operating instructions.

#### Warning:

The warning sign is shown above, which warns the user might get hurt

#### Caution:

The caution sign is shown above, it reminds the user that the instrument may malfunction or be damaged



The note sign is shown on the left, warns the user of important information about operation.

## Guarantee

Our company warrants the instrument for one year (12 months) from the date of delivery. Consumables and consumable parts in the equipment are not covered by the warranty. The terms of this warranty shall not apply if damage to the instrument occurs beyond the warranty period, or in the opinion of the company, the breakage or destruction of the instrument is due to improper use, lack of maintenance, improper installation, improper modification, abnormal environmental conditions, etc. The Company's obligation under this warranty is limited to providing replacement or repair of this product, as the case may be. The product must be thoroughly cleaned to remove any contaminated chemicals before it is accepted for replacement or repair. Our obligations shall not exceed the price of the product itself. In no event shall the company be liable for damage caused by incidental or consequential damages, whether to persons or objects. The Company shall not be liable for any other loss, damage or expense of any kind, including economic loss resulting from the installation, use or improper use of the product.

- For details, please refer to the product's quality promise with the product, and keep this manual and the quality promise properly.

# Contents

## Part 1 Introduction

<b>Chapter 1</b>	<b>Overview</b>	
	1.1 Technical Parameters . . . . .	1

## Part 2 Installation

<b>Chapter 2</b>	<b>Unpacking . . . . .</b>	<b>2</b>
<b>Chapter 3</b>	<b>Mechanical Installation</b>	
	3.1 Installation Location . . . . .	2
	3.2 Instrument Size . . . . .	3
	3.3 Panel Mounting . . . . .	3
<b>Chapter 4</b>	<b>Electrical Installation</b>	
	4.1 Power Connection . . . . .	4
	4.2 Wiring Terminals Definition . . . . .	5

## Part 3 Operation

<b>Chapter 5</b>	<b>User Interface</b>	
	5.1 Button . . . . .	6
	5.2 Display . . . . .	7
<b>Chapter 6</b>	<b>System Default Settings . . . . .</b>	<b>8</b>
<b>Chapter 7</b>	<b>Menu Description</b>	
	7.1 Probe Set . . . . .	10
	7.1.1 K Constant Set . . . . .	10
	7.1.2 Measuring Range Set . . . . .	10
	7.1.3 Probe Calibration . . . . .	10
	7.1.4 Temperature Compensation Coefficient . . . . .	11
	7.1.5 TDS Coefficient . . . . .	11
	7.1.6 Display Unit . . . . .	11
	7.2 Temperature set . . . . .	12
	7.2.1 Probe Type . . . . .	12
	7.2.2 Temperature Format . . . . .	12
	7.2.3 Temperature Calibration . . . . .	12
	7.2.4 Reset Calibration . . . . .	12
	7.3 Alarm Set . . . . .	12
	7.3.1 Control Function . . . . .	12

7.3.2	Cleaning Output	13
7.3.3	Cleaning State	13
7.3.4	ETEMP Alarm	13
7.4	Current Set	13
7.4.1	Output Type	14
7.4.2	Channel Selection	14
7.4.3	Upper Value	14
7.4.4	Lower Value	14
7.5	Communication Set	14
7.5.1	Slave ID	14
7.5.2	Baud Rate	14
7.5.3	Verify Bit	14
7.5.4	Stop Bit	14
7.6	System Set	14
7.6.1	Language	14
7.6.2	Display Speed	14
7.6.3	Backlight	14
7.6.4	Contrast set	14
7.6.5	Software	14
7.6.6	Password	14
7.7	Test Maintenance	15
7.7.1	Current Calibration	15
7.7.2	Relay Testing	15
7.7.3	Current Testing	15
7.7.4	Measurement Method	15
7.7.5	Ambient Temperature	15
7.7.6	Meter Reset	15
7.8	Setting List	15

## Part 4 Repair and Maintenance

### Chapter 8

#### General Remarks

8.1	Maintenance	16
8.2	Troubleshooting	17
8.3	Fault Checking	17

## Appendix

A	Modbus register information	18
---	-----------------------------	----

# Part 1 Introduction

## Chapter 1

### Overview

The online conductivity analyzer adopts a 2-electrode measurement method, which can be applied to various conductivity monitoring and control occasions.

#### 1.1 Technical parameters

Measuring Range	0.00~10.00mS/cm -10~+150°C
Resolution	0.01uS/cm, 0.1°C
Repeatability	0.3%FS
Citation Error	±1.0%FS
Temperature Compensation	NTC10K/PT1000 automatic or manual
Relay Control	
Channel Quantity	2
Control Type	Main measurement high/low alarm Temperature high/low alarm Ambient temperature alarm
Contact Type	SPST, software configurable always on/off
Contact Capacity	3A 250V AC
Current Output	
Channel Number	2
Corresponding Channels	Main measurement/TEMP
Output Type	Active 4~20mA or 0~20mA
Maximum Load	1000Ω
Communication Interface	A RS485 MODBUS-RTU
Operating Environment	0~60°C, RH 0~95%, no condensation
Storage Environment	-20~+70°C, RH 0~95%, no condensation
Power Requirement	18~36V DC 3W MAX
Installation Method	Panel mounting
Dimension	100*100*120mm
Protection Grade	IP66
Weight	500g



Note: The analyzer needs to be warmed up for 30 minutes after it is powered on, otherwise the measurement accuracy may exceed the nominal range.

## Part 2 Installation

### Chapter 2

#### Unpacking

After unpacking, it is recommended that the shipped cardboard boxes and packing materials be saved for instrument storage or reshipment. Inspect equipment and packing materials for signs of damage during shipment. If there are signs of damage, immediately notify the person delivering the shipment.

### Chapter 3

#### Mechanical Installation

### 3.1 Installation location

The installation location of the meter is:

Unaffected by weather (rain, snow, ice, dust, etc.)

- Clean, dry and with little or no vibration
- Keep away from corrosive liquids
- Within ambient temperature limits (32~140°F or 0~60°C)

**Caution:**

Analyzer directly exposed to the sun, its operating temperature may exceed its specified limit temperature, and will reduce the visibility of the display.



**Note:** Please read this operation manual thoroughly before installation to avoid damage to the instrument due to wrong wiring.

- Please choose a well-ventilated location to install the instrument to avoid direct sunlight.
- The electrode signal transmission must use specific cables or cables provided by our company, and cannot be replaced by random wires.
- When using AC220V power supply, avoid using three-phase power supply to avoid power spike interference (if power spike interference occurs, the power supply of the controller can be separated from the power supply of the control device, so that the controller uses a separate power supply, or the coil ends of all electromagnetic switches and power control devices are connected to spike absorbers to eliminate spikes, such as dosing machines, mixers, etc.).
- It is generally recommended that the controller be accessible to the electrode during installation.
- Avoid corrosive liquids, or need to protect and isolate the environment.

### 3.2 Instrument dimension

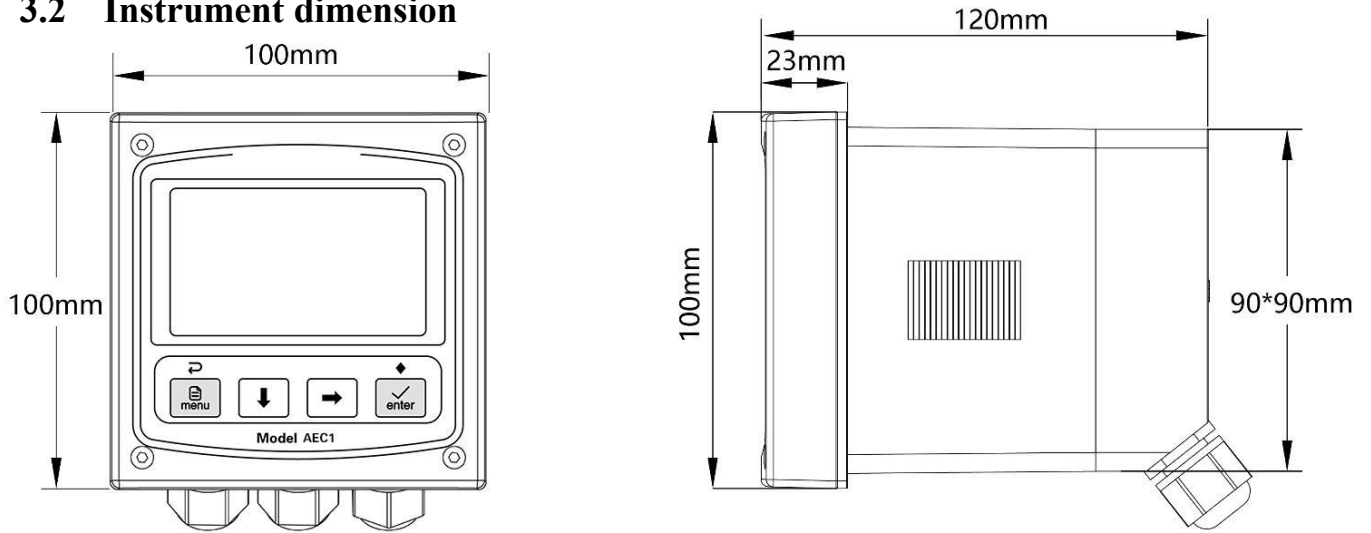

Figure 3-1 Instrument dimension

### 3.3 Panel mounting

When the instrument is selected for panel mounting, the user passes the fixing clips through the back of the instrument until it is tightened, and the mounting dimensions and diagram are shown below:

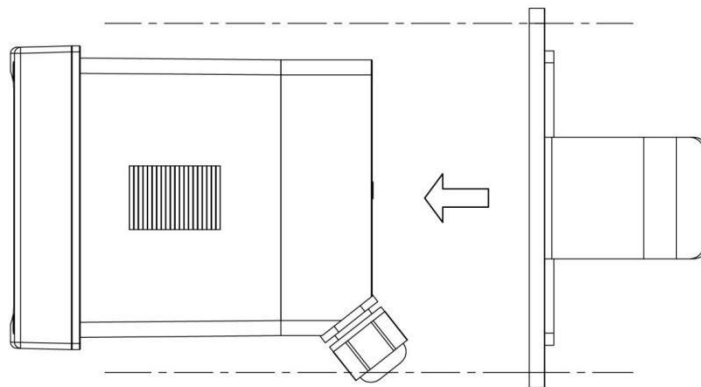

Figure 3-3 the minimum opening spacing when multiple meters are installed

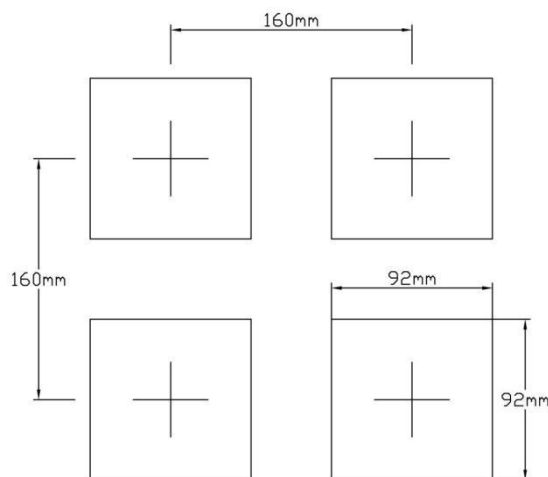

Figure 3-2 Panel mounting

### 4.1 Power connection

Two types of power supply: AC power supply 100~240VAC and DC power supply 18~36VDC. After unscrewing the screws at the back of the meter and taking off the cover, you can see two rows of terminals.



**Note:** Before connecting AC power, be sure to cut off the power supply and operate only in the power-off state.

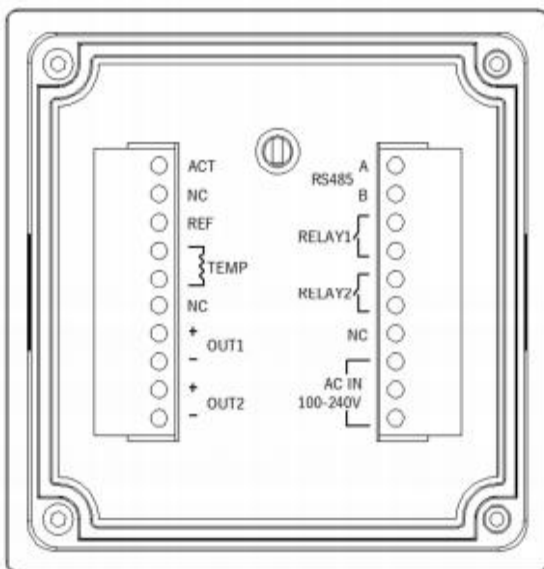

AC power supply: 100~240VAC

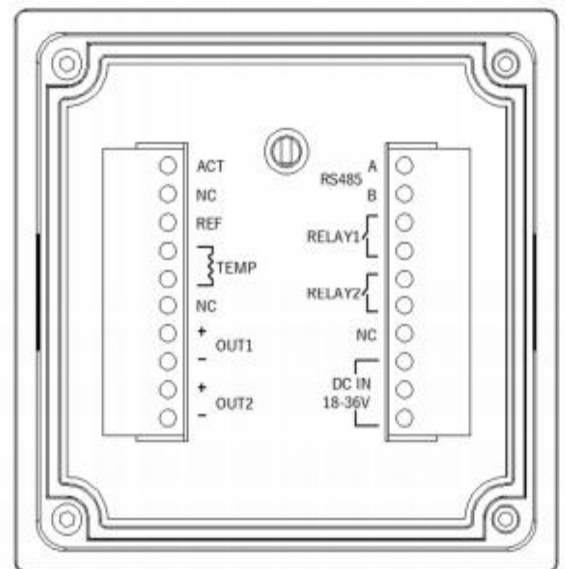

DC power supply: 18~36VDC

Figure 4-1 Two types of power

Two kinds of power terminals are defined in Table

POWER AC IN 100-240V	L	AC power fire wire input	POWER DC IN 18-36V	+	DC power positive
	⊕	AC power ground wire		NC	Floating terminal
	N	AC power zero line input		-	DC power negative

Table 4-1 Two types of power terminals

## 4.2 Wiring terminals

The terminal locations and names of each model series are shown in Figure 4-2:

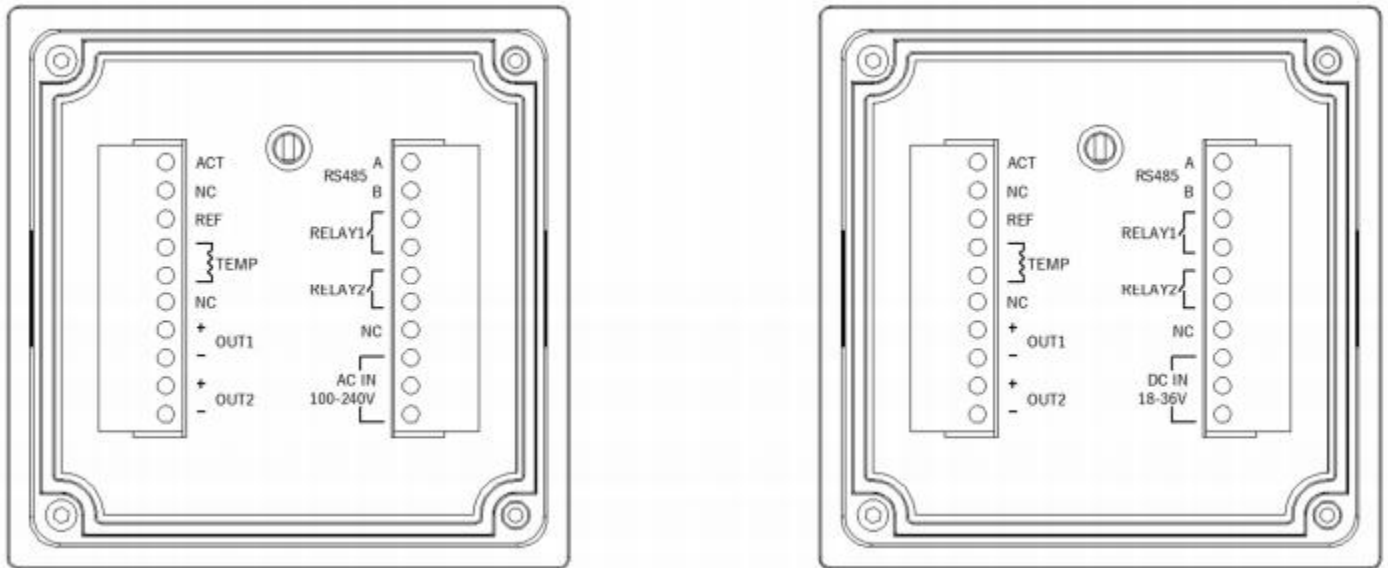

Figure 4-2 Terminals

The following table is the terminal definition:

ACT	Conductivity probe measuring terminal		RS485	A	RS485 signal D+(A) terminal
REF	Conductivity probe measuring terminal			B	RS485 signal D-(B) terminal
TEMP	Temperature probe input terminal		RELAY1	Relay 1 contact	
	Temperature probe input terminal			Relay 1 contact	
OUT1	+	Current 1 Output positive	RELAY2	Relay 2 contact	
	-	Current 1 Output negative		Relay 2 contact	
OUT2	+	Current 2 Output positive	NC	Floating terminals	
	-	Current 2 Output negative	NC	Floating terminal	

## Part 3 Operation



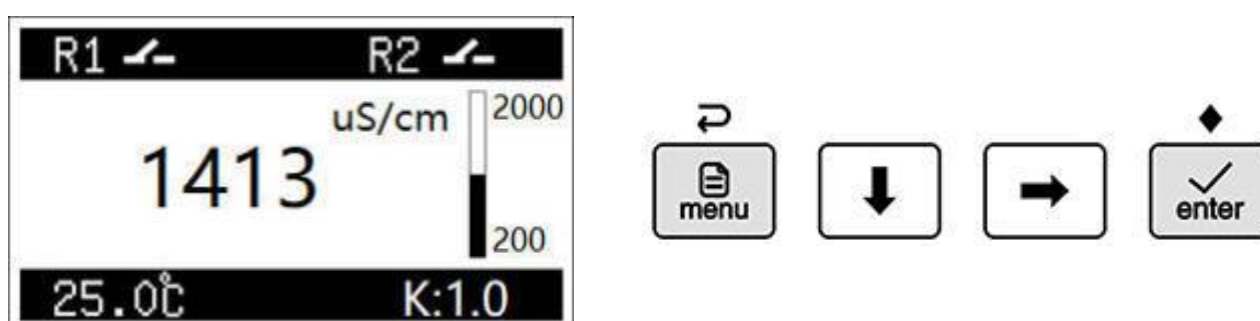

### Chapter 5

#### User Interface

The instrument panel consists of a display screen and four buttons, which are the MENU button, the ENTER button, and the down and the right direction button. As shown below:



#### 5.1 Button

Button	Function
	In the main menu, press this key to return to the measurement mode; In the sub menu, press this key to return to the previous menu; When setting the value, press this key to abandon the modification and return to the previous menu; During calibration, press this key to cancel the calibration process; In measurement mode, long press this key to enter the main menu.
	In measurement mode, press this key to switch between two secondary display modes; In the menu, press this key to move the cursor down; When setting the value, press this key to subtract 1 from the value, or to change the sign bit.
	In measurement mode, press this key to switch between four measurement value display modes (conductivity, resistivity, salinity, TDS); In the menu, press this key to move the cursor up; When setting the value, press this key to add 1 to the value.
	In the menu, press this key to enter the sub menu or the item selected by the cursor; When setting the parameter (value or option), press this key to save the setting and return to the previous menu.

## 5.2 Display

The meter normally displays the measurement interface after power-on. The specific information is as follows:

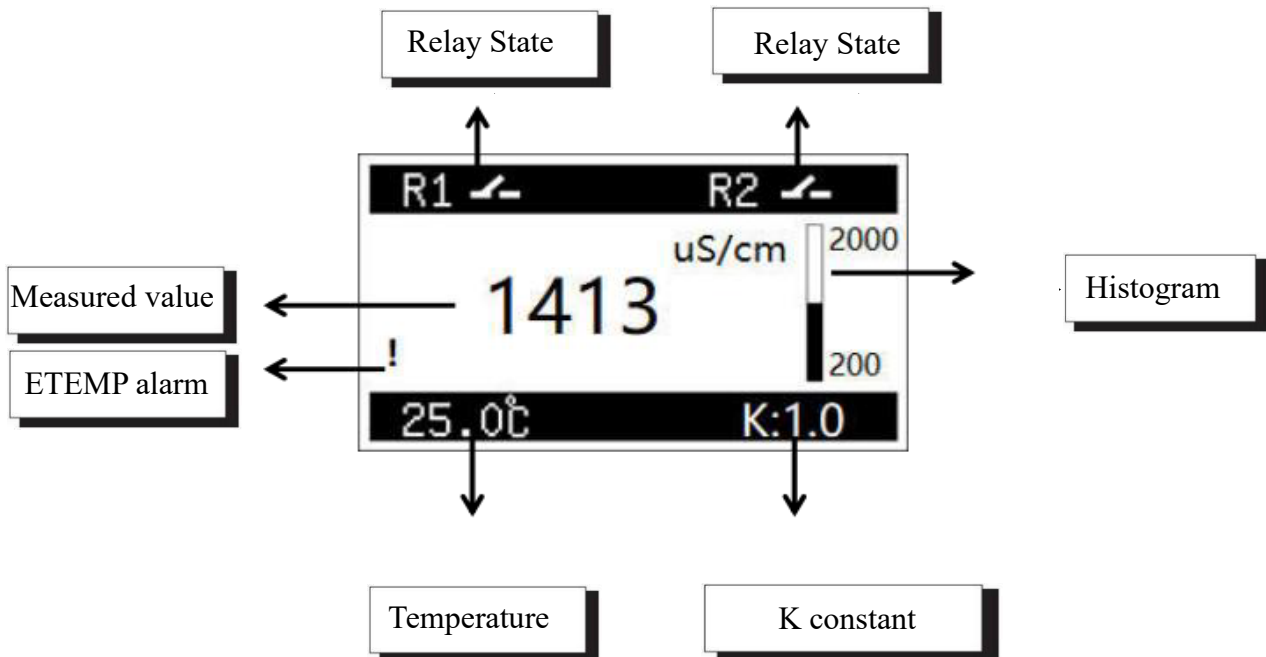

**Relay state:** Indicates the current relay state, on or off.

**Measured value:** Display the current measurement value, if “>” or “<” symbol appears in front of the measurement value, it means the measurement is out of range.

In measuring mode, press the button  to switch between “conductivity”→“resistivity”→“salinity”→“TDS”.

**Histogram:** Indicates the ratio of the current measured value to the range.

**ETEMP alarm:** When the operating environment temperature exceeds 50°C, a “!” will appear on the screen, indicating that the working environment temperature of the instrument is too high, and heat dissipation measures are needed.

**Temperature:** The temperature value is not displayed when the temperature electrode is not connected.

**K constant:** Displays the currently electrode K constant.

**System Default Settings**

Menu title		Input range or option	Factory settings
<b>Probe Set</b>			
K Constant Set		0~99.999	1.000
Range Set		AUTO, K20, K200, K2000, K10000	AUTO
Probe CAL	COND Offset	-999999~+999999uS/cm	0uS/cm
	COND Factor	0~99.999	1.000
	1ST Point CAL	0~999999uS/cm	86uS/cm
	2ND Point CAL	0~999999uS/cm	146uS/cm
	3RD Point CAL	0~999999uS/cm	1413uS/cm
	4TH Point CAL	0~999999uS/cm	4239uS/cm
	5TH Point CAL	0~999999uS/cm	12880uS/cm
TEMP C COEF		0~99.999%/°C	2.000%/°C
TDS COEF		0~99.999	0.500
Display Unit		AUTO, uS/cm, mS/cm	AUTO
<b>Temperature</b>			
Probe Type		NTC10K, PT1000, Manual	NTC10K
Display Format		xxx.x°C, xxx.x°F	xxx.x°C
TEMP Calibrate		-100.0~+100.0°C	+025.0°C
<b>Alarm Set</b>			
Relay I	Function Set	Cond Control, TEMP control, wash relay, ETEMP alarm	Cond Control
	On Value	0~999999uS/cm	10000uS/cm
	Off Value	0~999999uS/cm	9900uS/cm
Relay II	Function Set	Cond Control, TEMP control, wash relay, ETEMP alarm	Cond Control
	On Value	0~999999uS/cm	0uS/cm
	Off Value	0~999999uS/cm	100uS/cm

<b>Current Set</b>			
Current I	Output Type	4~20mA, 0~20mA	4~20mA
	Channel	Main CH, Temperature CH	Main CH
	Upper value	0~999999uS/cm	10000uS/cm
	Lower value	0~999999uS/cm	0uS/cm
Current II	Output type	4~20mA, 0~20mA	4~20mA
	Channel	Main CH, Temperature CH	Temperature CH
	Upper value	-10~150°C	100.0°C
	Lower value	-10~150°C	000.0°C
<b>Comm. Set</b>			
Slave ID	001~254Add		001Add
Baud rate	4800, 9600, 19200, 38400, 57600, 115200		9600
Verify bit	No parity, odd parity, even parity		No parity
Stop bit	1bit, 2bit		1bit
<b>System Set</b>			
Language	Chinese, English		English
Display speed	Buffers 2, buffers 4, buffers 8, buffers 16, buffers 32		Buffers 2
Backlight	Scanty power, always on		Scanty power
Scanty power	01min, 05mins, 10mins		01min
Contrast set	0~63		25
Password	000000~999999		000000
<b>Servings</b>			
Measure Mode	Probe Measure, Sim. Measure		Probe Measure
ETEMP Calibration	-999.9~+999.9°C		+025.0°C
ETEMP Alarm	OFF, ON		OFF

In the measurement interface, long press the MENU button to enter the menu. The following is a detailed introduction to the menu content.

## 7.1 Probe set

### 7.1.1 K constant set

Set the K constant value of the electrode connected to the instrument.

### 7.1.2 Measuring range set

Set the measurement range, the range expression method is "K\*range value", for example, when the electrode K constant is set to 0.1, the upper limit of the range "K200" measurement is 20uS/cm. It is generally recommended to use automatic range, the analyzer automatically switches the range according to the current measurement value.

### 7.1.3 Probe calibration

After the new electrode is connected to the analyzer, in order to eliminate the possible error between the electrode and the analyzer, the electrode needs to be calibrated first. The analyzer provides two calibration methods: two-point calibration and linear calibration.

The user can choose the calibration method according to the actual situation.

#### Two-point calibration

The analyzer provides two calibration parameters, "conductance deviation" and "conductivity factor". The user can select two standard solutions within the measurement range, calculate the deviation value and factor value, and enter it into the corresponding menu of the analyzer.

The relationship between the two calibration parameters and the measured value is:

**Conductivity measuring value = (original conductivity value \*factor) + offset**



**Tips: Two-point calibration is suitable for applications where the measurement value change range is relatively small.**

#### Two-point calibration process:

- (1) In the menu, set the "offset" to 0uS/cm, and the "factor" to 1.000;
  - (2) Put the electrode into the relatively low-concentration standard solution 1, and gently shake the electrode to ensure that there is no air bubble at the measuring end of the electrode affecting the measurement. After the value is stable, record the measured value 1;
  - (3) Rinse the electrode with pure water and absorb the residual water with filter paper. Put the electrode in the relatively high concentration standard solution 2, shake the electrode gently, and record the measured value 2 after the value is stable;
  - (4) Calculate "offset" and "factor"
- $$\text{Cond factor} = (\text{measured value 2} - \text{measured value 1}) / (\text{standard solution value 2} - \text{standard solution value 1})$$
- $$\text{Cond offset} = (\text{standard solution value 1} / \text{factor}) - \text{measured value 1}$$
- (5) Input "conductance offset" and "conductivity factor" into the corresponding menu.

## Linear calibration

For applications with a wide measurement range or high measurement accuracy requirements, the analyzer provides a linear calibration of up to 5 points, and the user can select 1 to 5 points to perform the calibration according to actual needs. The following uses three standard solutions to perform linear calibration as an example to illustrate the calibration process.

Prepare three standard solutions of 84uS/cm, 146uS/cm, and 1413uS/cm, and calibrate according to the following steps:

(1) Clean the electrode with deionized water and absorb the residual moisture with filter paper. Place the electrode in the 84uS/cm conductivity standard solution, Wait for the electrode measurement to stabilize, select "first point calibration" in the menu, enter 84,

press the key  to start the calibration, and wait for the end of the calibration;

(2) Clean the electrode with deionized water and absorb the residual moisture with filter paper. Place the electrode in the 146uS/cm conductivity standard solution, wait for the electrode measurement to stabilize, select "Second point calibration" in the menu, enter

146, and press  to start calibration, waiting for the end of calibration;

(3) Clean the electrode with deionized water and absorb the residual moisture with filter paper. Place the electrode in 1413uS/cm conductivity standard solution, wait for the electrode measurement to stabilize, select "Third point calibration" in the menu, enter

1413, and press  to start Calibration, waiting for the end of calibration;



**Note:** During the calibration process, the user can press the key  to forcibly end the calibration, but this method is not recommended, because it may cause the analyzer to perform calibration when the measurement is not stable.

**Tip:** During the calibration process, press  key to cancel the current calibration



**Note:** The standard solution value used for the calibration points can be selected arbitrarily. It is recommended to select the calibration points uniformly within the actual measurement range. The order of conductivity from low to high is required for calibration, point-by-point calibration, and the middle calibration cannot be skipped.



**Note:** The effect of the two-point calibration will be superimposed on the linear calibration. If you need to use both calibration methods at the same time, you need to perform the linear calibration first, and then perform the two-point calibration.

### Reset calibration

Reset the user calibration value to the factory default value.

#### 7.1.4 Temp compensation coefficient

Set the automatic temperature compensation coefficient, the unit is "%/°C".

#### 7.1.5 TDS coefficient

Set the TDS conversion factor, the TDS conversion relationship is:

$$\text{TDS value} = \text{conductivity value} * \text{TDS coefficient}$$

#### 7.1.6 Display unit

Set the conductivity display unit. When the unit is set to "Auto", the analyzer will automatically switch the display unit according to the current measurement value.

## 7.2 Temperature set

### 7.2.1 Probe type

When the meter is connected to a probe with temperature compensation, the menu needs to be set according to the temperature probe type. If you need to input the compensation temperature manually, you can select “Manual Compensation” and set the manual compensation temperature.

### 7.2.2 Temperature format

Select the temperature display unit, either “°C” or “°F”.

### 7.2.3 Tempe CAL

In this menu, enter the target tempe value and press the key  to calibrate the temp measurement to the entered target value.

### 7.2.4 Reset calibration

Reset the temperature calibration data to the factory default values.

## 7.3 Alarm set

The meter provides two completely independent relay output contacts, corresponding to the “Relay I” and “Relay II” menus, which allow the user to set the functions and parameters of the two relays separately.

### 7.3.1 Control function

When selecting “Main measurement control” or “Temperature control” in the “Main menu” -> “Alarm set” -> “Relay X” -> “Function set” menu, this relay is the control output relay. When “Main Measurement Control” is selected, the relay status is controlled by the conductivity measurement; when “Temperature Control” is selected, the relay is controlled by the temperature measurement.

When “on value” > “off value” is set in the menu, the relay is high alarm control

When “on value” < “off value” is set in the menu, the relay is low alarm control

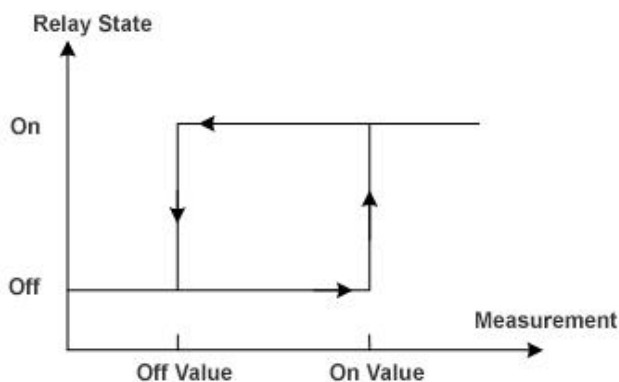

High alarm control

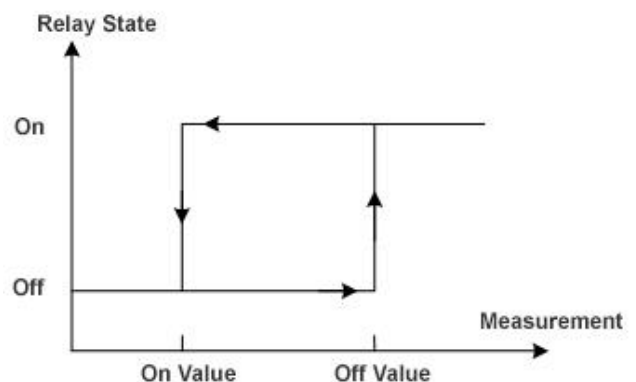

Low alarm control

### 7.3.2 Cleaning output

When selecting “Cleaning Output” in “Main Menu” -> “Alarm Set” -> “Relay X” -> “Function Set” menu , the relay is in the cleaning output state, the relay can be closed periodically to do cleaning control.

### 7.3.3 Cleaning state

Select the status of the measured value during cleaning.

After selecting “Keep”, when cleaning, the measured value displayed maintains the value before the relay action.

After selecting “Continuous”, the measured value is the real-time value of continuous measurement.

### 7.3.4 ETEMP alarm

When “ETEMP Alarm” is selected in the “Main Menu” -> “Alarm Set” -> “Relay X” -> “Function Set” menu, the relay is in the alarm control output state. The relay status is controlled by the meter's operating ambient temperature. When the ambient temperature exceeds 50° C, the relay closes.

## 7.4 Current set

The instrument provides up to two independently configurable current signals output, corresponding to the "Current 1" and "Current 2" menus, which allow the user to set the corresponding channels and the upper and lower limits of the two currents.

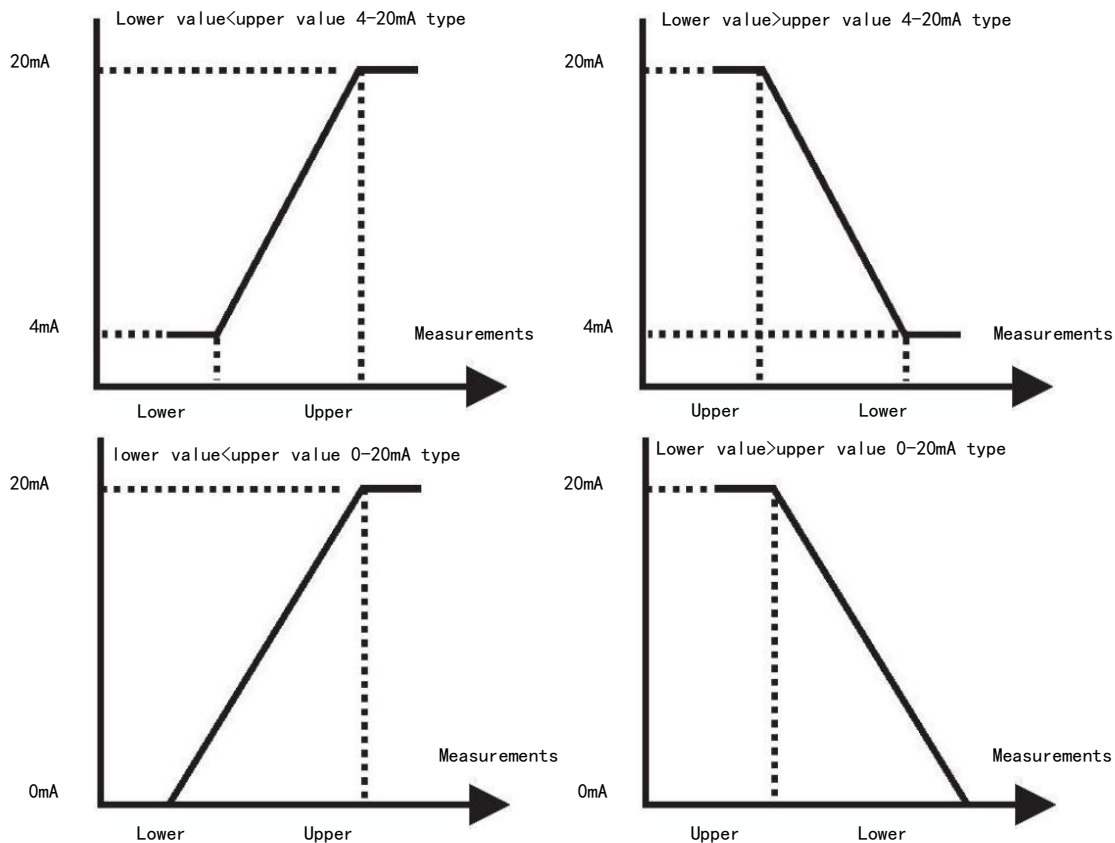

#### 7.4.1 Output type

The output current type can be selected as “4-20mA” or “0-20mA”.

#### 7.4.2 Channel selection

The measurement value corresponding to the current can be specified as the “main measurement channel” or “temperature channel”.

#### 7.4.3 Upper limit value

Specify the measured value corresponding to the maximum output current.

#### 7.4.4 Lower limit

Specify the measured value corresponding to the minimum output current.

### 7.5 Communication set

#### 7.5.1 Slave address

Sets the slave address used by the instrument in the communication network.

#### 7.5.2 Baud rate

Select the baud rate to be used for the communication interface.

#### 7.5.3 Check bit

Select the check mode, the default is “No parity”.

#### 7.5.4 Stop bit

Select the number of stop bits, the default is “one bit”.

### 7.6 System set

The instrument provides one digital communication interface, this menu can set the communication interface parameters.



#### 7.6.1 Display rate

Adjust the rate of the change of the measured display value. The display rate from fast to slow is “buffers 2” , “buffers 4” , “buffers 8” , “buffers 16” , and “buffers 32” .

#### 7.6.3 Backlight

Set the working mode of the LCD backlight. If it is set to “Scanty power” mode, the backlight will automatically turn off if there is no key operation within the set time.

#### 7.6.4 Contrast set

Set the contrast of the LCD display screen, key  to decrease the contrast, key  to increase the contrast.

#### 7.6.5 Software

View program version information.

#### 7.6.6 Password

Used to set the verification password to be entered when entering the menu in the measurement mode. The password is set to “000000”when leaving the factory, and you can enter the menu directly without password in the measurement mode. If the user sets other password, they will be prompted to enter the password when entering, and the password will be verified before entering the menu.

## 7.7 Test maintenance

### 7.7.1 Current CAL

To calibrate the current output value, take calibrating current 1 20mA as an example, first connect the ammeter to the current 1 output terminal, then enter the menu “Test Maintenance” -> “Current Calibration” -> “Current 1 “ -> “Calibrate 20mA”. Press the key to increase or decrease the value displayed on the screen until the ammeter reads 20mA, then press the key  to save the calibration result.

 **Note: When performing current calibration operation, for each current output, two points (4mA and 20mA) need to be calibrated to achieve the calibration effect.**

### 7.7.2 Relay testing

Two sets of relays can be tested for on or off.

After entering, select “close” or “open” and the corresponding relay will make an open or close action.

### 7.7.3 Current testing

Two current outputs can be tested. First, connect the ammeter to the current output terminal to be tested, enter the menu and change the output current value by pressing the key, and verify whether the meter current output is correct by the ammeter reading.

### 7.7.4 Measurement method

The measurement value can be set to “Electrode measurement” or “Analog measurement”.

Electrode measurement: The measured value displayed on the screen is the value measured by the electrode.

Analog measurement: The measured value is displayed as the input value set by the user.

### 7.7.5 Ambient TEMP

Ambient temperature value: Display the current ambient temperature value.

Ambient temperature calibration: Calibrate the ambient temperature measurement value of the meter.

Buzzer alarm: Set whether the buzzer outputs an alarm sound when the ambient temperature is alarmed.

### 7.7.6 Meter reset

The meter calibration parameters and all setting parameters can be reset to the factory default state.

## 7.8 Setting List

All calibration and setting parameters of the instrument can be viewed.

## Part 4 Repair and Maintenance

### Chapter 9

#### General Remarks

### 9.1 Maintenance

The meter and the probe contain precision parts. Please make sure that the meter and the probe will not be subjected to any strong mechanical impact during use. There are no user maintenance parts inside the instrument.

Maintenance cycle:

Maintenance item	Maintenance content	Maintenance cycle
Instrument test	Visual inspection, check whether the meter display is normal and whether the housing is	Every 4 weeks
Probe cleaning	Contamination and coverage of the probe surface will cause measurement error or measurement instability. The probe needs to be cleaned regularly during use. The cleaning agent can be clean water, 3-5% hydrochloric acid, daily detergent, etc.	7~15 days (According to the use environment, industrial wastewater is recommended to be cleaned once every 7~15 days)
Probe Calibration	Contamination and probe wear during probe use can cause measurement errors. Use standard solutions and periodically calibrate the probe in use to correct the error.	7~15 days (According to the use environment, industrial wastewater is recommended to be calibrated once in 7~15 days)

## 9.2 Troubleshooting

Fault phenomenon	Possible reason	Troubleshooting
No display	Power supply is not properly connected	Check if the power connection is normal and the power supply voltage is normal
	Incorrect contrast setting	Readjust the display contrast
The screen appears “!” prompt	Instrument temperature is too high	Lower the ambient temperature or increase heat dissipation measures
	Ambient temperature calibration error	Recalibrate the measured value of the meter's ambient temperature
Data communication does not respond	Data line polarity is	Correct the polarity connection of the data
	Communication parameter setting error	Check and reset communication parameters (slave address, baud rate, parity)
	Communication cable	Replace or repair cables
Communication data error	Slave address conflict	Check whether the instrument slave address conflicts with other devices in the network and reset the slave address
Inaccurate current output	Parameter setting error	Check and reset current parameters
	Load impedance is too high	Check if the wire is too long or the load impedance is too high, and correct
	Current output drift generates errors	Recalibrate the current output in the test maintenance menu

## 9.3 Fault checking

Judgment items	Judgment method
Whether the relay is normal	Switch between “close” and “open” in the test maintenance menu, listen to whether the relay has an action sound, and measure whether the resistance value of the relay is less than 10 $\Omega$ when the relay is closed with a multimeter
Whether the current output is normal	Remove the wire of the current output terminal of the meter, connect the ammeter to the current output terminal of the meter, set different current values in the current test menu, and observe whether the ammeter reading is the same as the value set in the menu

# Appendix

## A Modbus register information

### 1. Modbus RTU Overview:

The instrument acts as a slave on the network and supports the Modbus RTU communication protocol. The data communication is initiated by the host and the first byte of the transmitted message is the target slave address. When the first byte is received by all slaves on the network, each slave will decode it to determine whether the message is sent to itself.

The transmission of the RTU message frame starts with a pause interval of at least 3.5 characters. After the last character is transmitted, a pause of at least 3.5 characters marks the end of the message frame. A new message can start after this pause. In the transmission process, the entire message frame must be transmitted in a continuous stream. If there is a pause of more than 1.5 characters before the completion of the message frame transmission, the receiving device will refresh the incomplete message and assume that the next byte is the start of the new message. Similarly, if a new message starts after the previous message frame in less than 3.5 character, the receiving device will assume that it is a continuation of the previous frame, and this will cause an error because the last CRC value cannot be correct.

The meter uses the function code 0x04 to complete the output of the measurement result and the output of the two current values.

### 2. Function code details (function code 0×04):

This function enables the host (upper computer) to obtain the real-time measured value from the slave (instrument). The value is specified as a single-precision floating-point type (that is, occupying 2 consecutive register addresses), and the corresponding parameter are marked by different register address.

The host can send the command frames to read single or all data results. The data frame format is as follows (all data are in Hex format):

Host send:

1	2	3	4	5	6	7	8
Slave address	Function code	Register start Address	Register start address	Register number high 8 bit	Register number low 8 bit	CRC low 8 bit	CRC high 8 bit
Addr	04	xx	xx	xx	xx	CRC	CRC

Slave response:

1	2	3	4	5	5+n	5+n+1	5+n+2	5+n+3
Device Address	Function code	Length	Data 1 high 8	Data 1 low 8 bit	Data n high 8 bit	Data n low 8	CRC low 8	CRC high 8
Addr	04	Len	xx	xx	xx	xx	CRC	CRC



Note :

1. Addr is the slave address, with an optional range of 0 x 01 to 0 x FE.
2. Len is the number of bytes of returned data.

Examples:

Send frame: [01 04 00 02 00 02 D0 0B], the meaning is as follows:

[01]: Instrument address

[04]: Function code

[00 02]: Starting register address 0 x 02

[00 02]: Read 2 registers from the start address (read a single-precision floating-point data result)

[D0 0B]: CRC check data

Return frame: [01 04 04 CC CD 41 48 65 4D], the meaning is as follows:

[01]: Instrument address

[04]: Function code

[04]: The number of bytes returned (here 4)

[CC CD 41 48]: 0 x 4148CCCD (12.55 floating-point values, specific numerical meaning to find the corresponding address) (Note: 16-bit integer registers coalition of a single-precision floating-point, pay attention to the order of the data)

[65 4D]: CRC check data

### 3. Corresponding parameter table of communication

Numbering from address 0 is as follows:

00	Temperature value (°C)
02	Conductivity value (uS/cm)
04	Resistivity value (MΩ ▪ cm)
06	Current 1 (mA)
08	Current 2 (mA)
10	Ambient temperature value (°C)
12	TDS value(ppm)
14	Salinity(ppt)

## Conductivity electrode



### specification parameter:

Range: 0.01~200  $\mu$  S/cm

Electrode mode: 2-electrode type

Electrode constant:  $K \approx 0.1$

Liquid interface material: 316L

Temperature: 0°C~150°C

Pressure: 0~2.0Mpa

Temperature sensor: PT1000

Installation interface: chuck 50.5

Cable: Standard length is 10 meters.

### Number

Name	Content	Number
Temperature sensor	PT1000	P2
Cable length	5m	m5
	10m	m10
	15m	m15
	20m	m20
Cable connector	Tinned	A1
	Fork terminal	A2
	Flat pin header	A3

